



MAGIC SWITCH CHROMA (ADV)

CONTACTLESS KNOWING ACT SENSOR FOR AUTOMATIC DOORS

KR

제품 설명

매립 설치 시

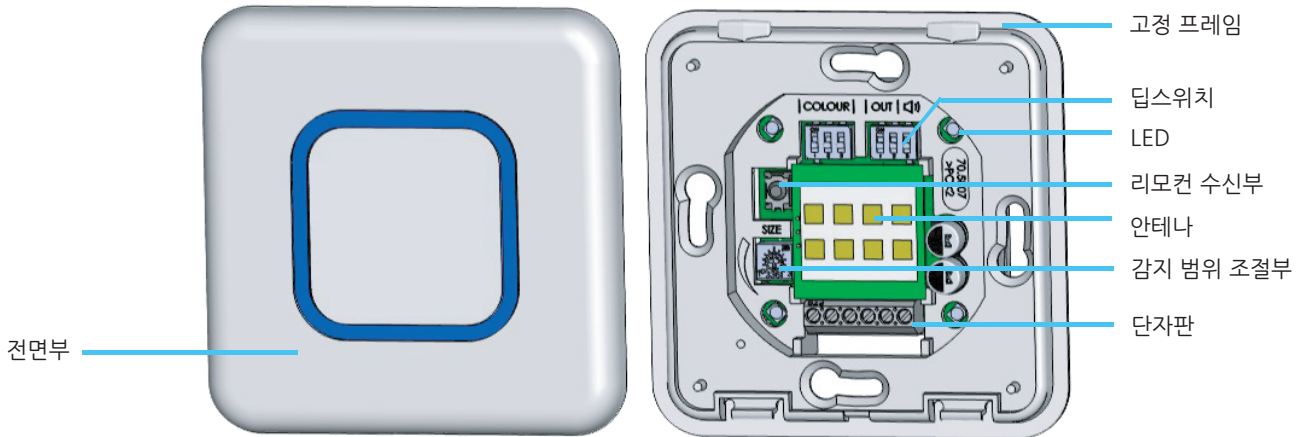

거치 설치 시

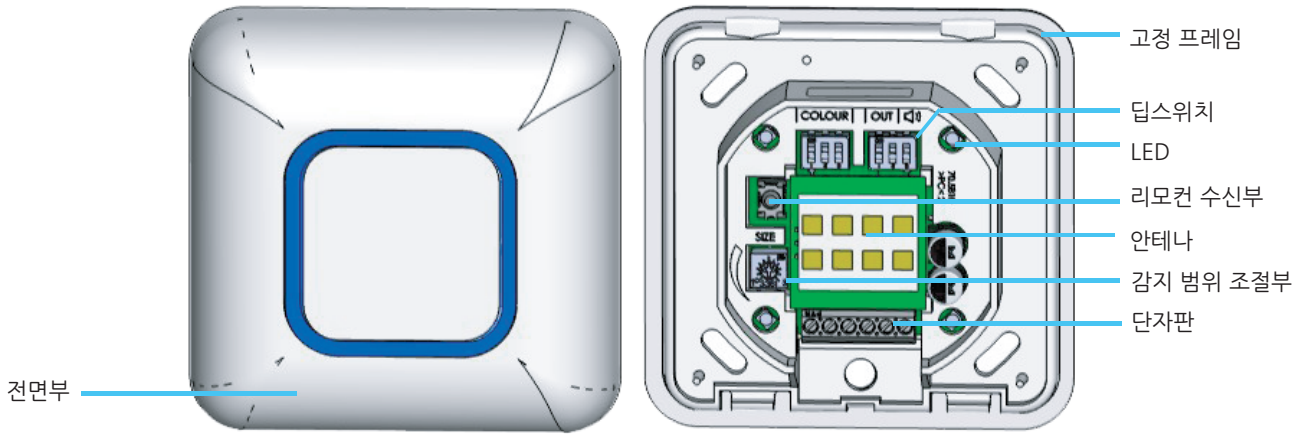

FEATURES

- 항균 처리된 제품
- 다양한 LED 효과 선택 가능
- IP65
- 토글 기능
- 사운드 선택 가능
- 리모컨으로 설정 조정
- 외부 신호 입력을 통한 애플리케이션 중심 설정

설치

매립 설치 시

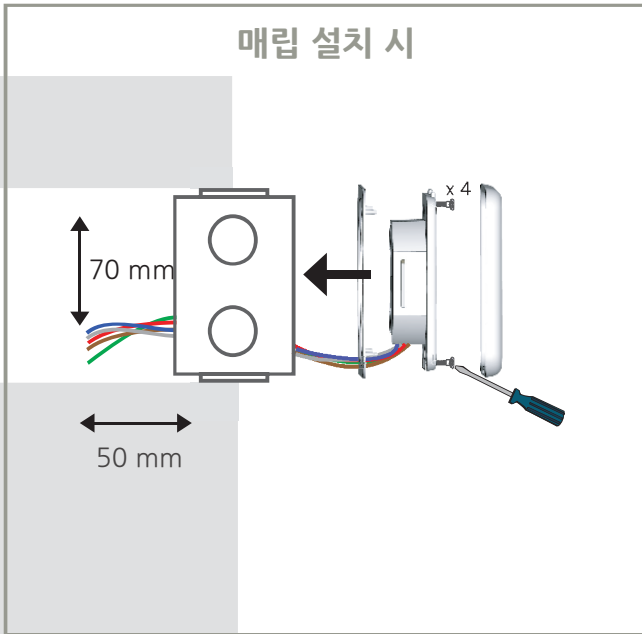

거치 설치 시

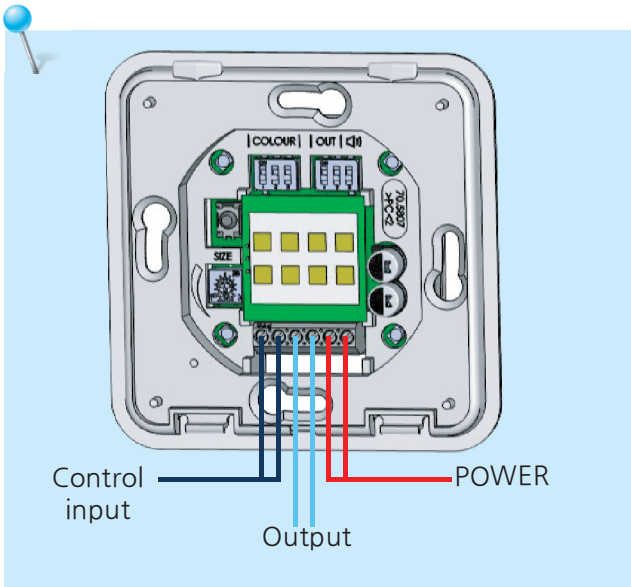
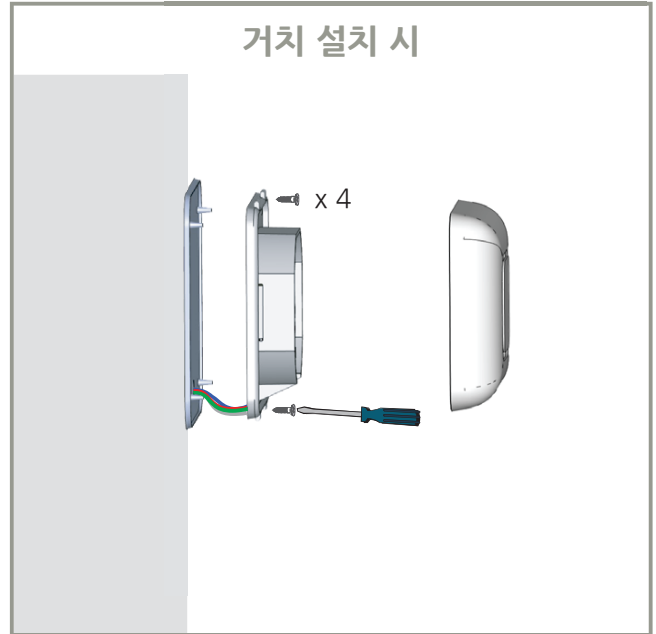

CLOSE

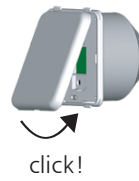

OPEN

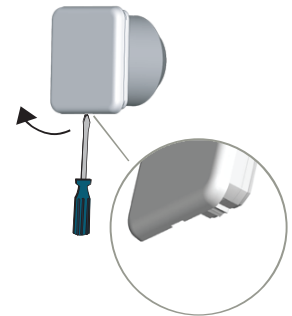

조정 방법

1 감지영역

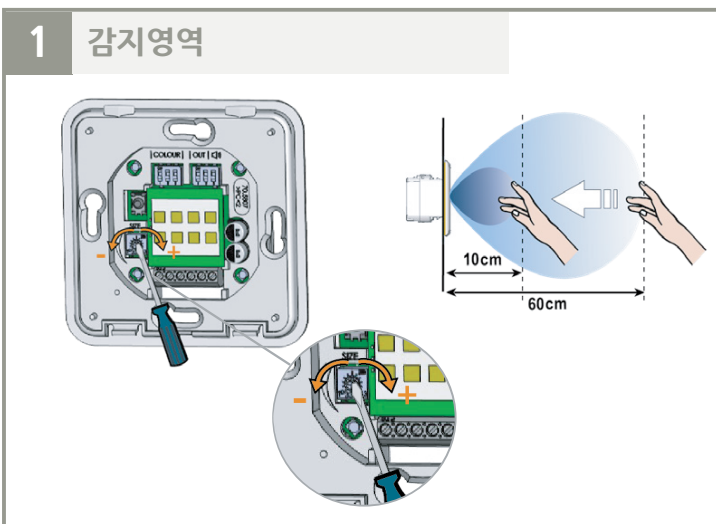

2 DIP스위치 세팅

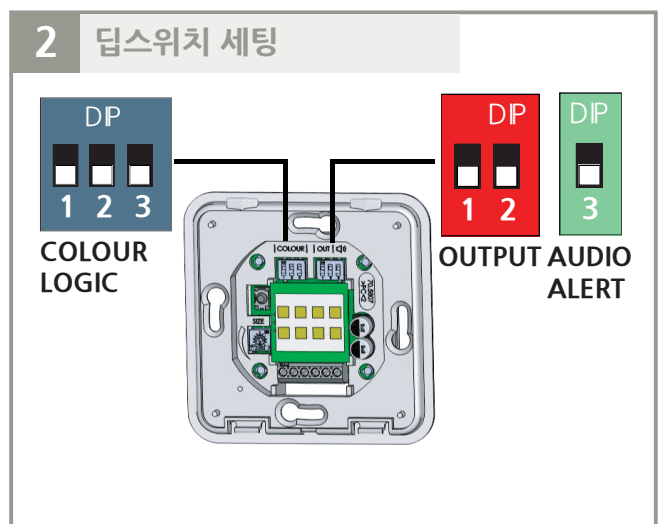

COLOUR LOGIC

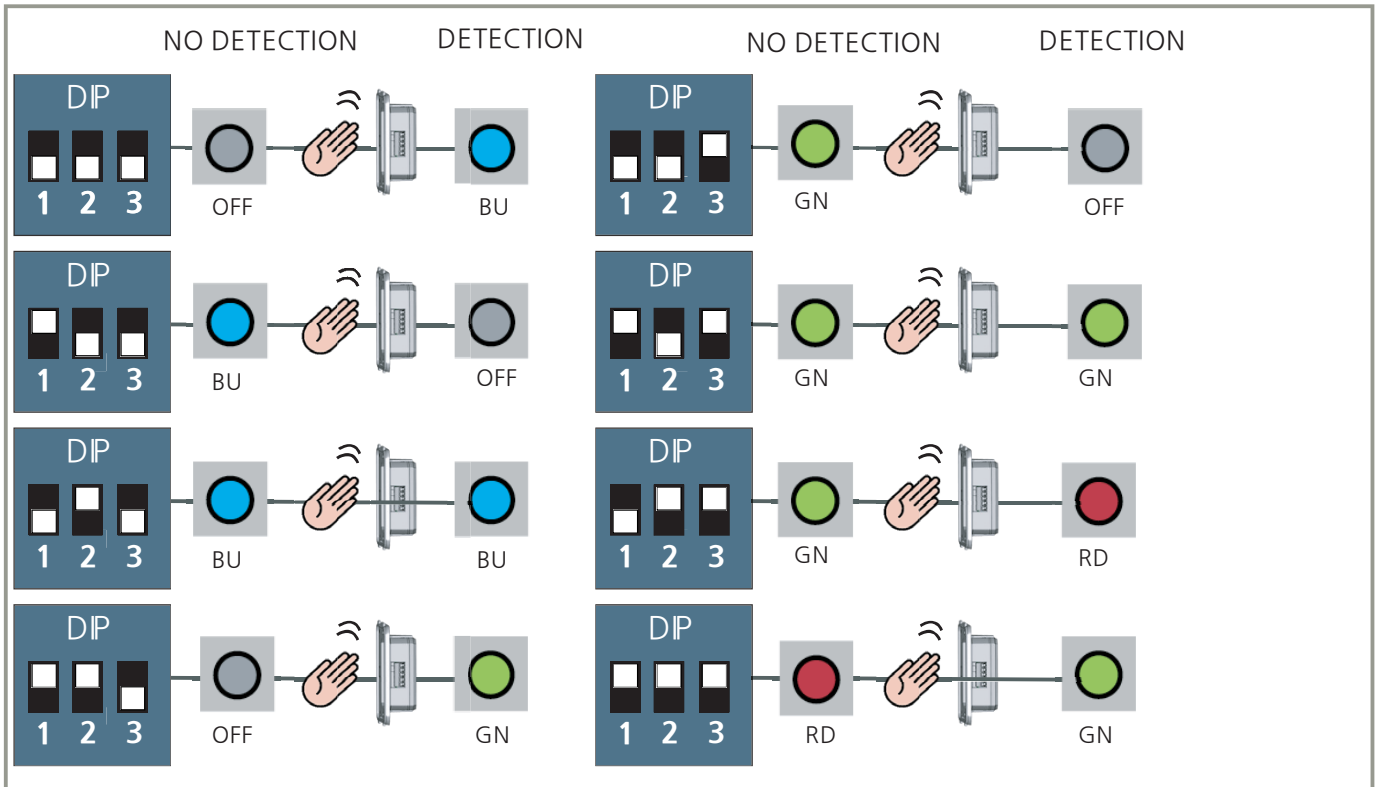

OUTPUT MODE

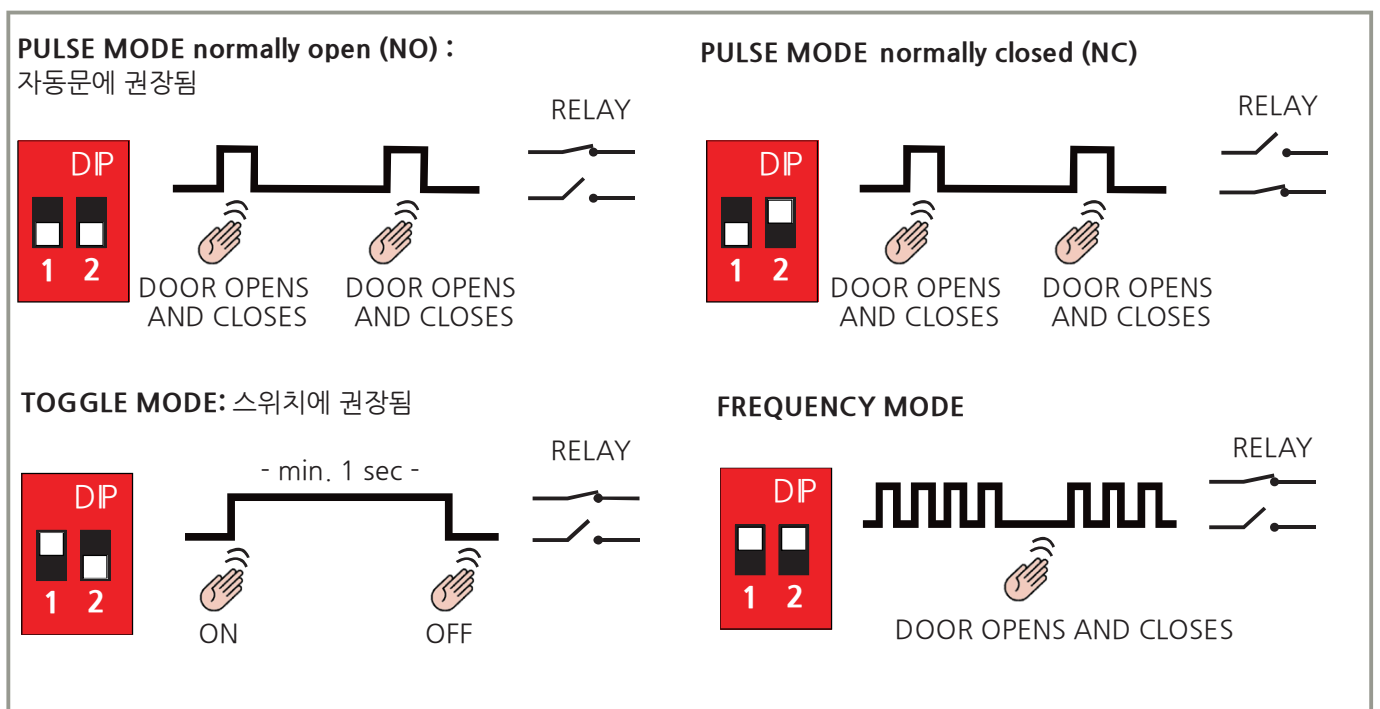

CONTROL INPUT

입력을 외부 신호에 연결하여 LED 색상을 적용합니다.

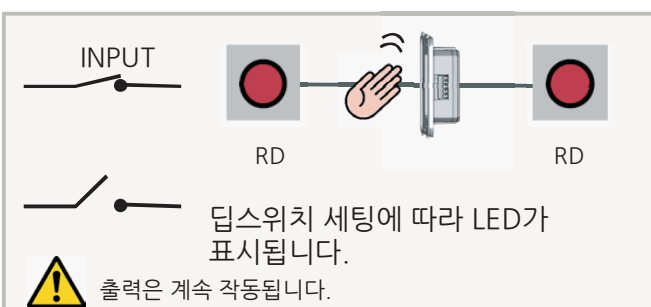

AUDIO ALERT

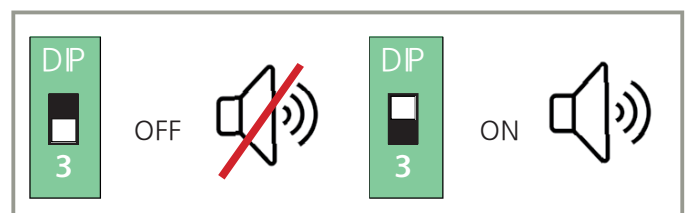

HOW TO USE THE REMOTE CONTROL



After unlocking, the red LED flashes and the sensor can be adjusted by remote control.



If the red LED flashes quickly after unlocking, you need to enter an access code from 1 to 4 digits. If you do not know the access code **and restore the power supply**. During 1 minute, you can access the sensor without introducing any access code.



To end an adjustment session, always lock the sensor.

SAVING AN ACCESS CODE

The access code is recommended for sensors installed close to each other.



DELETING AN ACCESS CODE



ADJUSTING ONE OR MORE PARAMETERS



RESTORING TO FACTORY VALUES



FIELD SIZE

FIELD SIZE

In order to change these settings by remote control, adjust the potentiometer to minimum

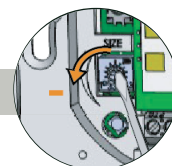

OUTPUT

OUTPUT MODE

In order to change these settings by remote control, adjust the 2 DIP switches to OFF



HOLD TIME



LED 조정

LED 색상 설정

리모컨으로 이러한 설정을 변경하려면 3 개의 DIP 스위치를 OFF로 조정하십시오.

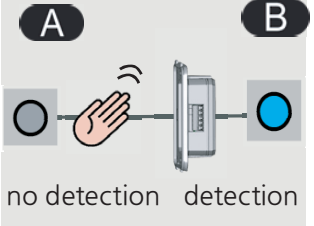
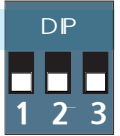

	0	1	2	3	4	5	6	7
		or	or	or	or			
A	OFF	Red	Green	Blue	Yellow	Pink	Turquoise	White
B	OFF	Red	Green	Blue	Yellow	Pink	Turquoise	White

예시 :

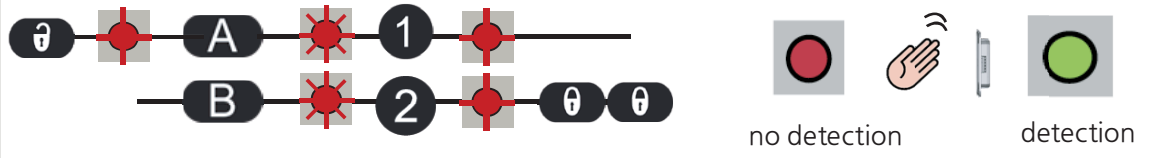

애니메이션 동작 효과

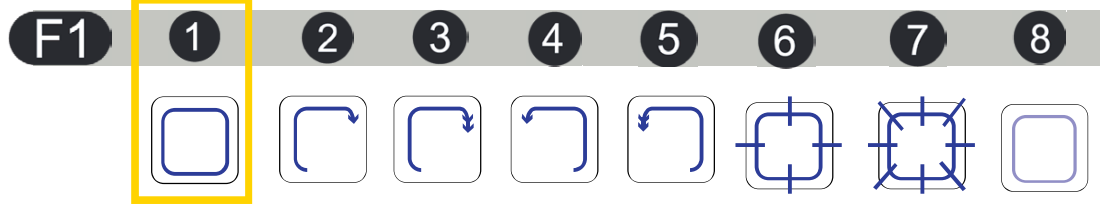

밝기 조정

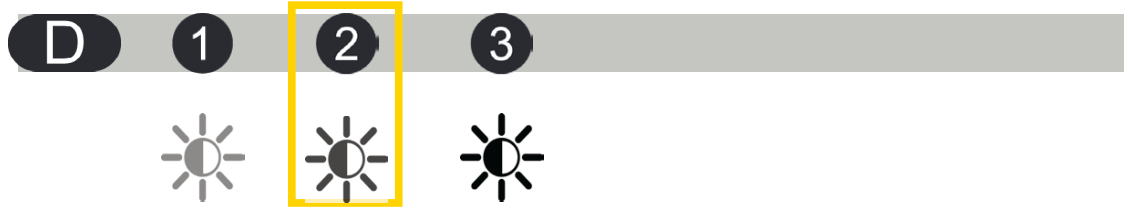

사운드 조정

사운드 톤 조정



Factory value

사운드 신호 조정

리모컨으로 이러한 설정을 변경하려면 3 개의 DIP 스위치를 OFF로 조정하십시오.

DP
3

	no detection	detection
0		
1		
2		
3		
4		

● 짧게
 — 길게

CONTROL INPUT

컨트롤 인풋이 활성화 되었을 때, LED와 사운드 효과 확인

LED 색상 로직

DIP스위치 조정에 따른 LED 색상

0	1	2	3	4	5	6	7
	or	or	or	or			
OFF	Red	Green	Blue	Yellow	Pink	Turquoise	White

애니메이션 동작 효과

F2	1	2	3	4	5	6	7	8

Factory value

사운드 신호 조정

no detection

detection

	no detection	detection
0		
1		
2		
3		
4		
5		
6		
7		

● 짧게
 — 길게

오류 진단 및 해결

센서쪽으로 손을 움직여도 문이 열리지 않음	전원 공급이 안됨	전원 확인 필요
	감지 범위가 너무 짧음	감지 범위 조정 센서 앞에 금속 물체가 있다면 치워주십시오
	잘못된 결선 / 연결	결선과 릴레이 연결을 확인하십시오
센서가 계속 감지 됨	주변 환경이 센서에 영향을 줌	센서 주변의 움직이는 물체들을 치우십시오
	잘못된 결선 / 연결	결선과 릴레이 연결을 확인하십시오
감지 후 도어가 계속 열려있음	잘못된 아웃풋 모드	아웃풋 모드를 펄스(PULSE) 모드로 변경하십시오
	잘못된 결선 / 연결	결선과 릴레이 연결을 확인하십시오

기술사양

기술 :	마이크로웨이브
주파수 :	24.150 GHz
방사 전력 :	< 20 dBm EIRP
Radiated power density	2< 5mW/cm
감지거리 :	+/- 10 ~ 60 cm (센서와 수직 방향으로 근접했을 때)
감지모드 :	움직임 감지 (양방향)
감지속도 :	최소 5Hz or +/- 3cm/s, 최대 200Hz or +/- 1.2m/s
공급전압	12 - 24V AC +/- 10% 12 - 24V DC +30% / - 10%
이 제품은 Class II SELV 전용 전원으로 전원을 공급해야 합니다. 이 요구 사항은 1차 전압과 센서 전원 사이의 이중 절연을 필요로 합니다. 공급 전류는 1.5A로 제한되어야 합니다.	
메인주파수 :	50 - 60 Hz
소비전력 :	< 1.5W
출력	Electronic relay (galvanic isolation - polarity free)
최대인가전압 :	42V AC/DC
최대인가전류 :	100mA
출력유지시간	0.5s (in PULSE mode)
사용가능온도 :	-20°C to +55°C
외부보호등급 :	IP65, (front face and gasket mounted on a smooth surface)
재질	PMMA / PC Front face is treated with biomaster silver biocide tested to ISO 22196:2011. Please use biocides responsibly.
추천 케이블 길이	기본 케이블 16 AWG - 1.5mm

* An adjustment of the detection field below 10 cm is possible but the detection capability of the sensor can not be guaranteed.

SENSORium / 경기도 하남시 덕풍3동 조정대로 150 ITECO 651 센서리움 • KOREA
T+82 (0) 31 795 5077 / F+82 (0) 31 790 1034 / E info@sensorium.co.kr



BEA hereby declares that the Magic Switch is in compliance with European Directives 2014/53/EU (RED) and 2011/65/EU (RoHS).
The full text of the EU declaration of conformity is available on our website.

This product should be disposed of separately from unsorted municipal waste

